



省權實業股份有限公司
SHENG CHYEAN ENTERPRISE CO., LTD.

鹿港廠 LUGANG
505 台灣彰化縣鹿港鎮輔導路360巷17號
No.17, Lane 360, Fudao Rd., Lugang Township,
Changhua County, Taiwan (R.O.C)
Tel: +886-4-7746666 Fax: +886-4-7742255

線西廠 HSIENHSI
507 台灣彰化縣線西鄉寓埔村寓埔路217-1號
No.217-1, Yu-Pu Rd., Yu-Pu Village, Hsienhsi Hsiang,
Changhua County, Taiwan (R.O.C.)
Tel: +886-4-7588533 Fax: +886-4-7588500

e-mail: tw.sc@msa.hinet.net
www.tw-sc.com.tw

DO OUR BEST

產品型錄

SHENG CHYEAN

WE ARE THE PROFESSIONAL
MANUFACTURER OF BAR-MAKING MACHINERY



公司簡介

COMPANY INTRODUCTION

省權的機器產品已銷售至世界各地，包含台灣、中國、德國、美國、俄羅斯、印度、土耳其、中東等多個國家和地區，並獲得良好的信譽。精良的生產設備，先進的工藝方法，為我們生產優質產品提供了強有力的保證。

顧客滿意是我們的宗旨，不斷攀升是我們的追求，省權將始終堅持以人為本的方針更全面和深入地投身於有色金屬和非有色金屬材料的加工製造中，以更多、更全、更優的產品來滿足國內外廣大客戶對產品的需求。

SHENG CHYEAN's machines have already been sold to many countries in the world, including Taiwan, China, Germany, U.S.A, Russia, India, Turkey, Middle East, and so on, and get nice reputation. Excellent advanced machinery and process are the warranty of our qualified products.

Customer's satisfaction is our tenet, and non-stop development is our purpose. SHENG CHYEAN will insist on being based on people and technique, and deeply engage in the ferrous and non-ferrous metal fabrication, and will meet the need of national and international customers' requirement with more complete and more qualified products.

Do our best To work together with one heart

寧可千日緊，不可一日鬆！
Constancy is the foundation of success.

經營者願景

VISION OF THE OPERATOR



省權成立於1994年，近20年以客為尊，高度客製化、且不斷修正及改善，並以自有品牌行銷德國、日本、中東等國，遍及全世界已開發及開發中的國家。

不斷的創新和持續提高產品質量是我們在競爭激烈的市場中脫穎而出的法寶。時至今日，我們更以不斷壯大的研發能力、嚴格的品質管理、領先的技術、以及完善的銷售和服務，與全球客戶一起分享做人的成果。

我們強調以人為本觀念及盡力提供員工培訓和改善員工工作生活品質，教育再教育！

代表省權管理層與全體員工，感謝世界各地顧客持續的信任和支援，今後我們將以「世界性、國際性的省權」為目標向前邁進，盼各先進多予指導、批評。

請與我們聯絡及給我們機會為您提供提高品質和生產力的設備。

SHENG CHYEAN has been established in 1994. In 20 years, "CUSTOMER FIRST" is our first target. Our product can be made according to customer's requirement and always keep improving. Nowadays, we sell our machine with OBM (Ordinance Bench Mark) to Germany, Japan, Middle East and other developed countries and developing countries.

Nonstop innovations and high quality products are our target for getting lasting success in a fiercely competitive market. Up till now, with our powerful forces of R&D, strict quality control, advanced technology and perfect networks of sales and services, we are enjoying the achievements together with global customers

We insist on people-oriented concept and makes great efforts to offer training chance and improve the quality of employees' life. CONTINUOUS EDUCATION is the power to push us forward.

On behalf of the management and staff of Sheng Chyeon, I would like to thank our customers for their continuing confidence and support. To assist us in communicating with the international market, we welcome any comments or queries regarding our products and services.

Please contact with us and give us a chance to offer you machines that can increase the quality and productivity.

黃裕權
Yu Chuan Huang

We are the professional
Manufacturer of bar-making machinery



穩健成長 認真投入
客製創新 專業開發
品牌翌立 永續經營
服務全面 共創雙贏

面對日新月異的二十一世紀與國際間開發中國家的工業興起，市場的要求更加多變與嚴苛。

唯有不斷在既有產品的工藝提昇，更迫切在新產品的研發，來滿足各種顧客的需求，進而提昇省權的價值。

We are facing twenty one century which is changed everyday and a lot of developing countries are spring up. The market is becoming more change and more difficult.

We keep promoting the technical of products and focus on the investigation of new product to satisfy customer's requirement for increasing the value of SHENG CHYEAN.

Professional
Technology

不斷創造新的存在價值。
To create new existence value continuous.



Professional Technology

公司沿革

History of SHENG CHYEAN

自1994年，省權提供棒材生產設備檢修服務、販售自動化零件，之後投入研發有色金屬及非有色金屬棒材生產設備，目前已經獲得德國、日本、美國、韓國、俄羅斯、土耳其、台灣、中國大陸、印度、泰國、越南等各國大廠的青睞，銷售足跡遍及世界。

Since 1994, Sheng Chyeon offered the inspection service of bar-making equipment and sold the automatic parts. Then, we start to manufacture the equipment for the ferrous and non-ferrous bar equipment. Until now, we have already got the order from Germany, Japan, U.S.A., Korea, Russia, Turkey, Taiwan, China, India, Thailand, Vietnam and etc.

- | | |
|--|---|
| 1995 -取得ISO-9001認證 | 1995 -Acquired ISO9001 certification |
| 1999 -於大陸嘉興出口加工區設立公司 | 1999 -Established new company in Jiaxing Export Processing Zone, China. |
| 2000 -於大陸東莞設立公司 | 2000 -Established new company in Dongguan ,China. |
| 2001 對大陸提供整廠輸出。 | 2001 -We provided the whole plant export to CHINA. |
| -於泰國設立公司 | -Established new company in Thailand. |
| -於印度設立營業處 | -Established office in India. |
| 2003 對印度提供整廠輸出。 | 2003 -We provided the whole plant export to India. |
| -於土耳其設立營業處 | -Established office in Turkey. |
| -取得CE認證 | -Acquired CE certification |
| 2005 對土耳其提供整廠輸出。 | 2005 -We provided the whole plant export to Turkey. |
| -於南非設立營業處 | -Established office in South Africa. |
| 2006 -於德國設立營業處 | 2006 -Established office in Germany. |
| 2007 -於台灣彰化興建第二廠房 | 2007 -Constructed second plant in Changhua County,Taiwan |
| -對德國提供整廠輸出。 | -We provided the whole plant export to Germany. |
| -於韓國設立營業處 | -Established office in Korea. |
| 2008 -於台灣彰化興建第三廠房 | 2008 -Constructed third plant in Changhua County, Taiwan |
| -擴大組織並加強營業人員訓練 | -Expand our business and enhance job training for our employees. |
| -於莫斯科設立營業處 | -Established office in Moscow. |
| 2009 -於台灣彰化興建第四廠房 | 2009 -Constructed fourth plant in Changhua County, Taiwan |
| 2010 -公司名稱由省權實業有限公司，更名為省權實業股份有限公司 | 2010 -Company name changed from limited company to incorporated company. |
| 2011 -創立群創廠，生產線軌、異型材，及削皮代工。 | 2011 -Established Chiun Chuang Precision Technology Co., Ltd. to manufacture the gliding rail and irregular bar and peeling process. |
| 2012 -成功拓展銷售地區至東歐、南美等國。 | 2012 -Success to sell the machines to East Europe and South America. |
| 2013 -創立台灣省全精密，生產線軌、異型材，及削皮代工。 | 2013 -Established Sheng Chuan Precision Technology Co., Ltd. to manufacture the gliding rail, irregular bar and peeling process. |

Do our best To work together with one heart



We are the professional
Manufacturer of bar-making machinery

海外企業/公司組織表/省權團隊

省權
SHENG CHYEAN



Related Enterprise/Team

- 台灣省權一、二、三廠：
機器設計、組立及出貨，並負責各地區的售後服務。
- 台灣隆奕廠：
零件加工，並設有多台CNC車、銑床設備。
- 台灣省全精密廠：
生產異型材，並為客戶進行削皮代工。
- 嘉善省全：
為大陸華中、華北地區客戶，提供銷貨及售後服務。
- 東莞省全：
為大陸華南客戶，提供銷貨及售後服務；並提供部份零組件生產。
- TAIWAN SHENG CHYEAN:
To provide the machine design, assembly, shipment and after-service for each area.
- TAIWAN LUNGYI:
Parts processing with several CNC lathe and miller equipment.
- TAIWAN SHENG CHUAN:
To provide the irregular bar material and peeling processing.
- CHINA JIASHAN:
To provide the sales and after-service for the customers in central and north of China.
- CHINA DONGGUAN:
To provide the sales and after-service for the customers in south of China, and manufacture some parts and assembly.



Do our best To work together with one heart



We are the professional
Manufacturer of bar-making machinery

銷售地區分布圖

Sales geographical distribution



Self-Reliant Processing

自主加工

SELF-RELIANT PROCESSING

我們擁有高度的自主零件加工能力，廠內有多台的車床及銑床，可生產所有在設備上需求的零件，同時也可對外提供加工的服務。

We have the ability to manufacture the parts by ourselves. In our plant, we have many lathes and millers. These machines can manufacture the parts that our equipment requires. Also, they also can manufacture the parts to provide external customers.



Do our best

To work together with one heart



We are the professional
Manufacturer of bar-making machinery

線軌加工&削皮代工

Gliding rail manufacture & Peeling processing

台灣省權主要生產線軌產品，並為客戶進行削皮代工。
Taiwan Sheng Chye Precision mainly provides the gliding rail product and the peeling processing

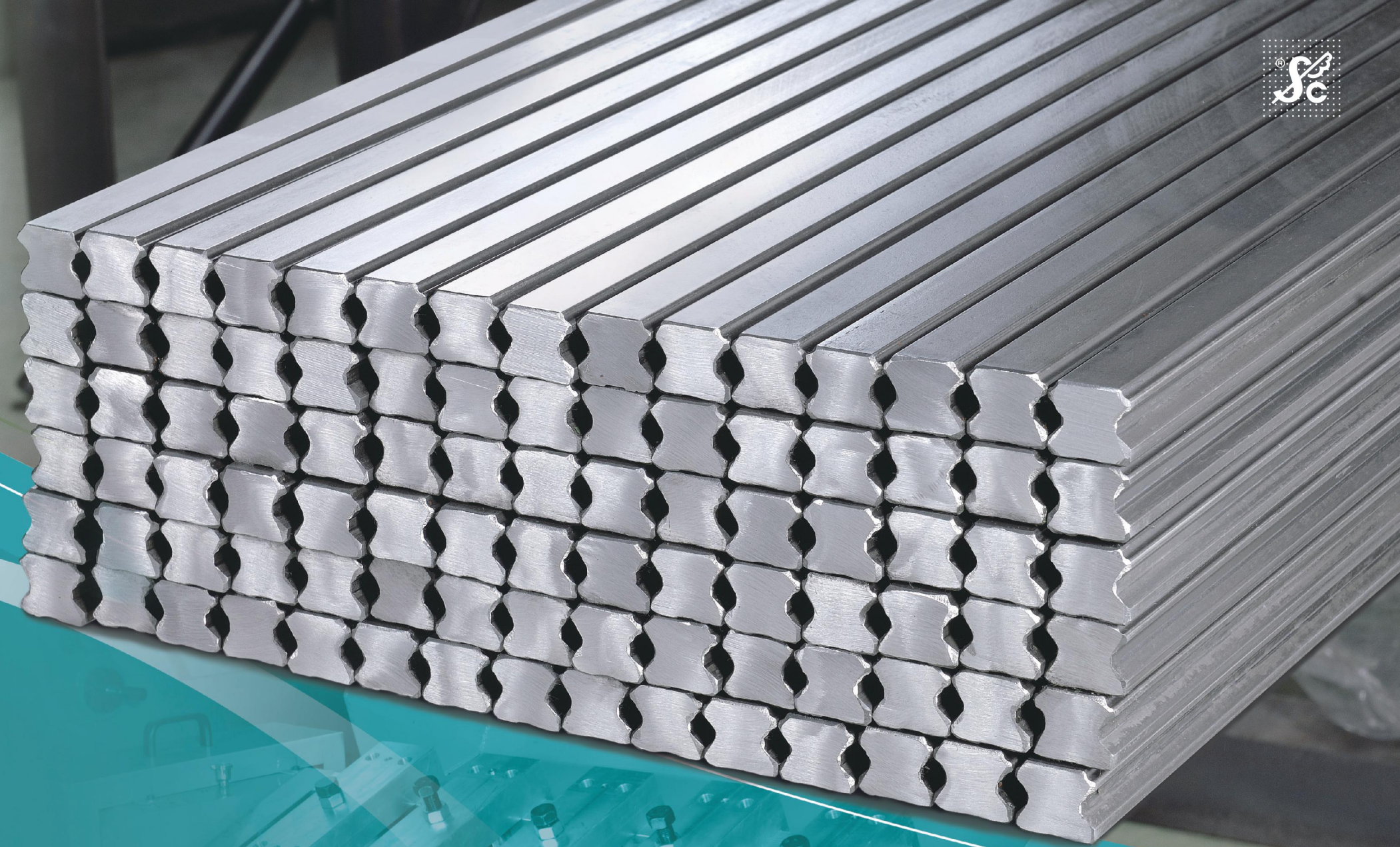
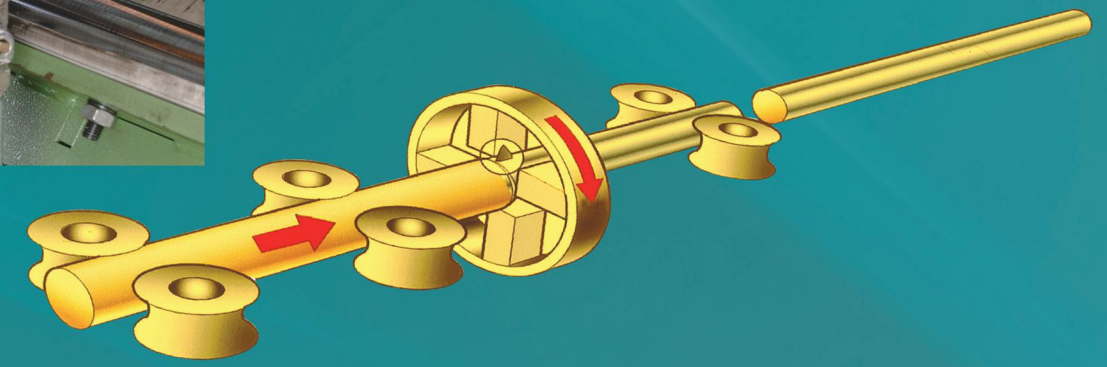
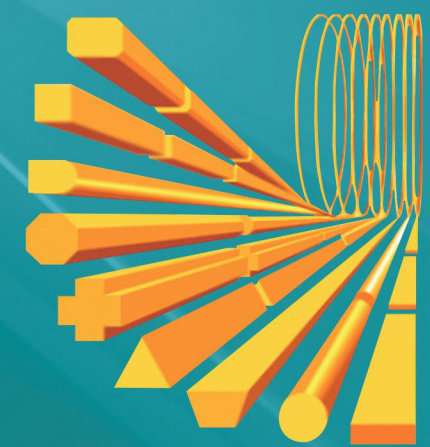
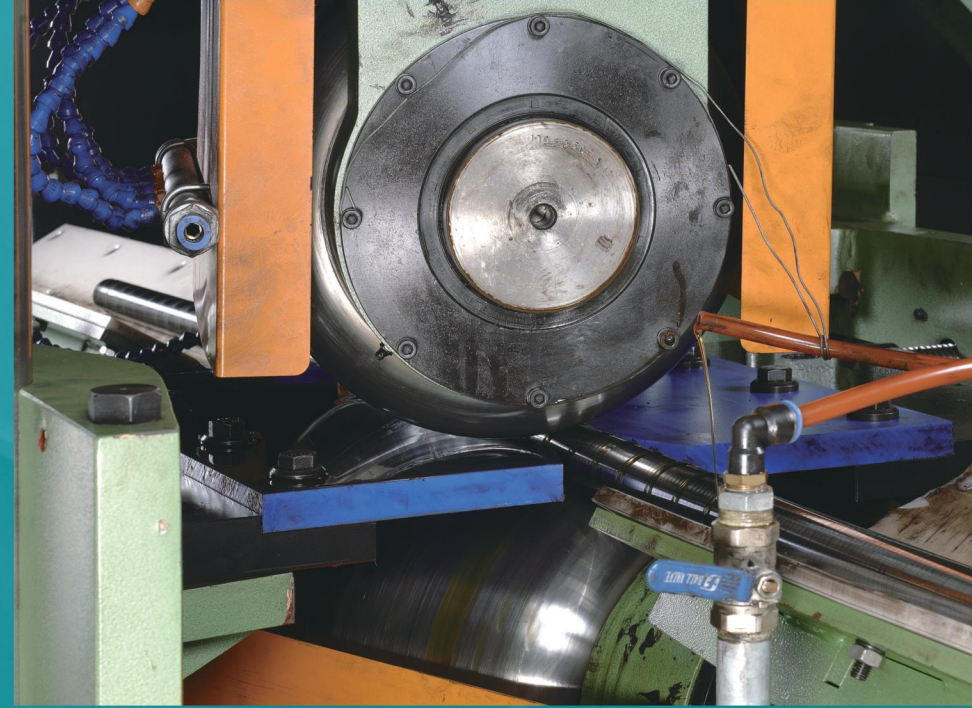

Do our best To work together with one heart

We are the professional
Manufacturer of bar-making machinery



品質認證
Quality Certification

Quality Certification



Product

To work together with one heart
Do our best



我們製造的複合式伸棒機透過複合式組合，生產可以達到高效率且同時保證成品最高質量。除了複合式伸棒機，我們可以提供棒材生產線前後匹配的各项裝置，例如：

- 開盤機
 - 擠頭機
 - 旋轉矯直機
 - 修頭機
 - 倒角機
 - 噴砂機
 - 軋/束頭機
- (上述部份裝置為選配)

Our combined drawing machine is complex combination, and the production will be high-efficiency and guarantee to achieve best quality. Except the combined drawing machine, we can offer below devices that can match the production line.

- Coil Opener
 - Push Pointer
 - Straightening and Polishing Machine
 - Pointing Machine
 - Chamfering Machine
 - Shot Blasting Machine
 - Swaging Machine
- (Above are option items.)



We are the professional
Manufacturer of bar-making machinery

拉拔段

DRAWING SET

鑄件為FC25級以上，其底座一體成型加工及組裝，精度高且強固。並改變以往方形滑軌及V型滑軌的設計，全部改用直線滑軌，其耐用性及替換性可達高水準；雙凸輪採合金鑄造，以五軸加工機加工，其精密度及耐用性可長時間運轉而不磨耗，拉拔滑座往返之動作確實。

The casting part is above FC25 level and the base is machined and assembled in one piece. It is high precision and strong. All rectangular rail and V shape rail were replaced with linear rail to provide better durability and substitute nature. Twin cam is manufactured by casting with alloy and processed by 5 axis machining center. The precision and durability can afford long-time running without wear and it can make the movement of the gliding set is indeed.



動態剪切

DYNAMIC SHEAR

採用伺服馬達為台車動力，齒輪齒條傳動，搭配高精度線性滑軌，並採用油壓剪切。

Using servo motor for driving the cutting unit and the gear wheel and rack are the transmission. Besides, collocate high precision linear rail and use oil hydraulic cutting.

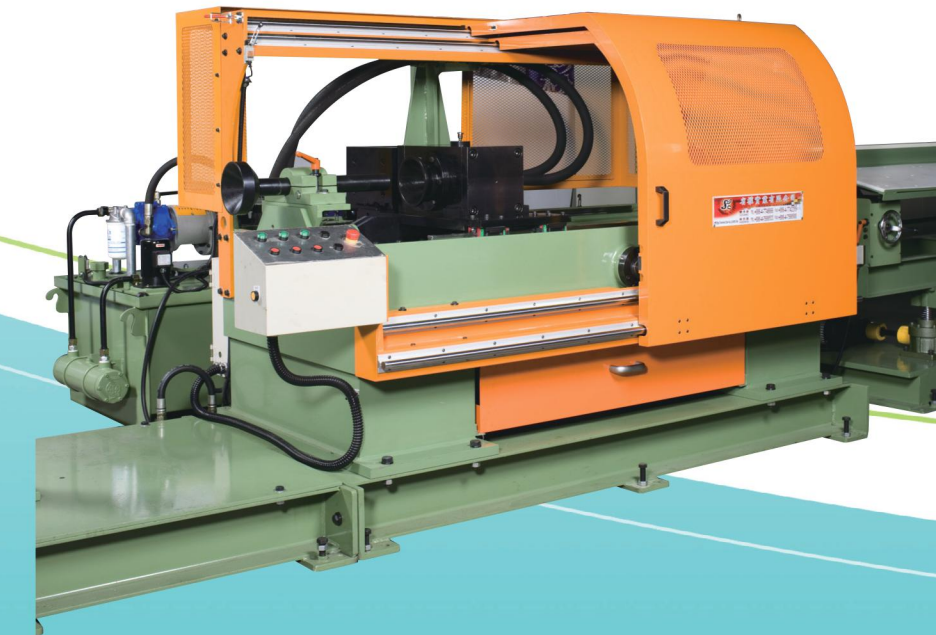



We are the professional
Manufacturer of bar-making machinery

拋光矯直機

POLISHING AND STRAIGHTENING MACHINE

拋光矯直機使用二對錫鋼拋光盤及配置5-7個錫鋼矯直環，同時可矯直和拋光棒材。
此機台運轉透過潤滑油循環，使拋光盤、矯直環及棒材獲得最佳的潤滑。

The polishing and straightening machine equips with two pairs of polishing disc and five to seven straightening rings that simultaneously straighten and polish the bar.

During the machine running, lubricant is circulated continuously which achieves best lubrication for the polishing disc, straightening ring and bars.



立式圓棒矯直機

VERTICAL ROUND BAR STRAIGHTENING MACHINE

本設備由一個凹輓與一個凸輓所組成的，除了通過兩輓所達到的矯直外，並有壓光的效果，更有人機的參數設定，對棒材加工作一系列的記憶設定。

This machine is equipped with one concave and one convex roller. The bar passed two rollers can get the straightness and polish efficiency. Moreover, this machine equips the MMI (touch monitor) to set the parameter and can have the memory setting for different bar size.



開盤機

COIL OPENER

開盤機能較快速且容易地將大線徑的盤捲頭端拉出。在進入預矯直機前，線材彎曲的部份會經由矯直輓輪矯直。(此裝置為選配)

The coil opener can speedy and easily pull out the end of large diameter wire coils. The crooked part of the wire will pass through the straightening rollers and be straightened. (This unit is option)



油壓擠頭機

HYDRAULIC PUSH POINTER

油壓擠頭機構利用油壓動力，將線材推進並使線材進入拉拔眼模。(適用直徑18mm以上)(此裝置為選配)

The push pointer mechanism uses hydraulic power to push the wire end into the drawing die (This is only suitable for the wires over 18mm diameter). (This unit is option)

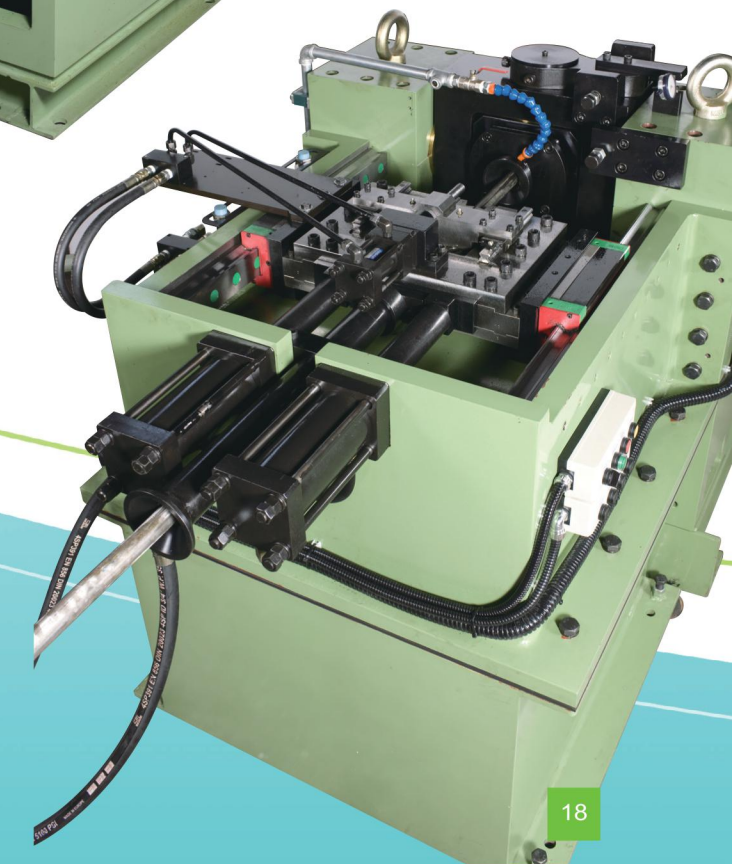



We are the professional
Manufacturer of bar-making machinery

旋轉矯直機

STRAIGHTENING AND POLISHING MACHINE

利用棒材通過旋轉並以可調整的鎢鋼矯直環，加以矯直。其優點就是使棒材的全圓周都能平均得到矯直，使棒材應力消除，獲得較佳的品質改善。

The bar is straightened with adjustable tungsten straightening ring by the rotating.

The advantage is to make whole circle of the bar to get the straight. Then, the stress of the bar will be eliminated and the bar can get better quality improvement.

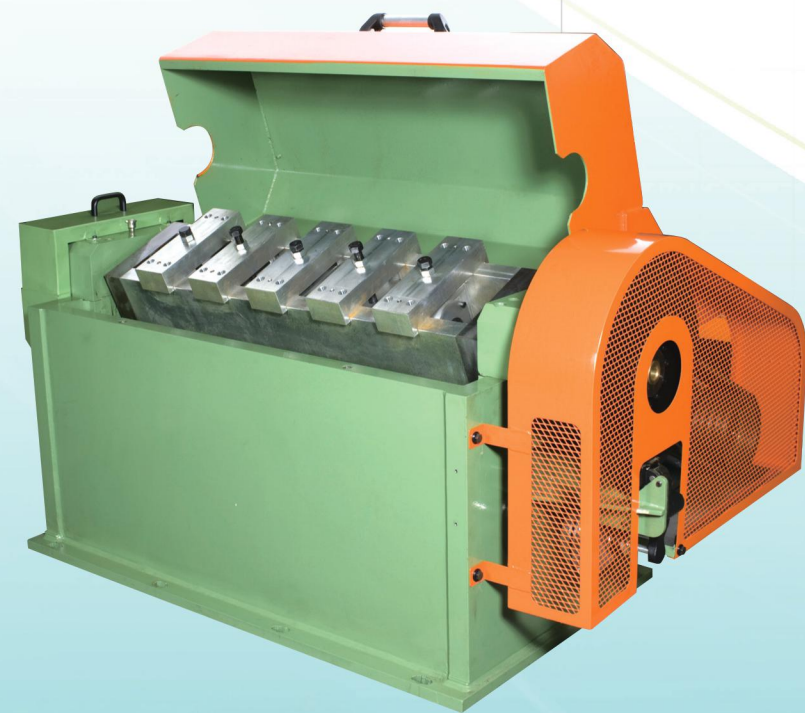

修頭機

POINTING MACHINE

線材進入抽伸眼模之前，必須先將線材的頭部外徑加工，以便讓線材通過眼模。修頭機的功用即為能將線材的斷面縮小。

Before the coil enter the drawing die, the end of the coil should be reduced the diameter for passing the drawing die. The function of the pointing machine is to reduce the diameter of the end of the coil.

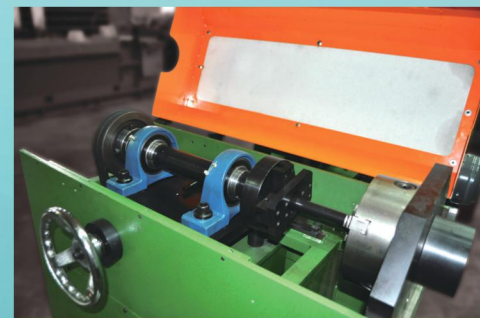

鏈式伸棒機

CHAIN DRAW BENCH

此冷伸拉設備可生產多種管材、棒材類產品，生產的直徑範圍較大，也可以選擇性搭配單支拉拔或多支拉拔的型態。

This cold drawing equipment can manufacture many kinds of tube and bar production. The diameter range of the production is bigger. Also, it can equip single tube/ bar or multi-tube/ bar type.

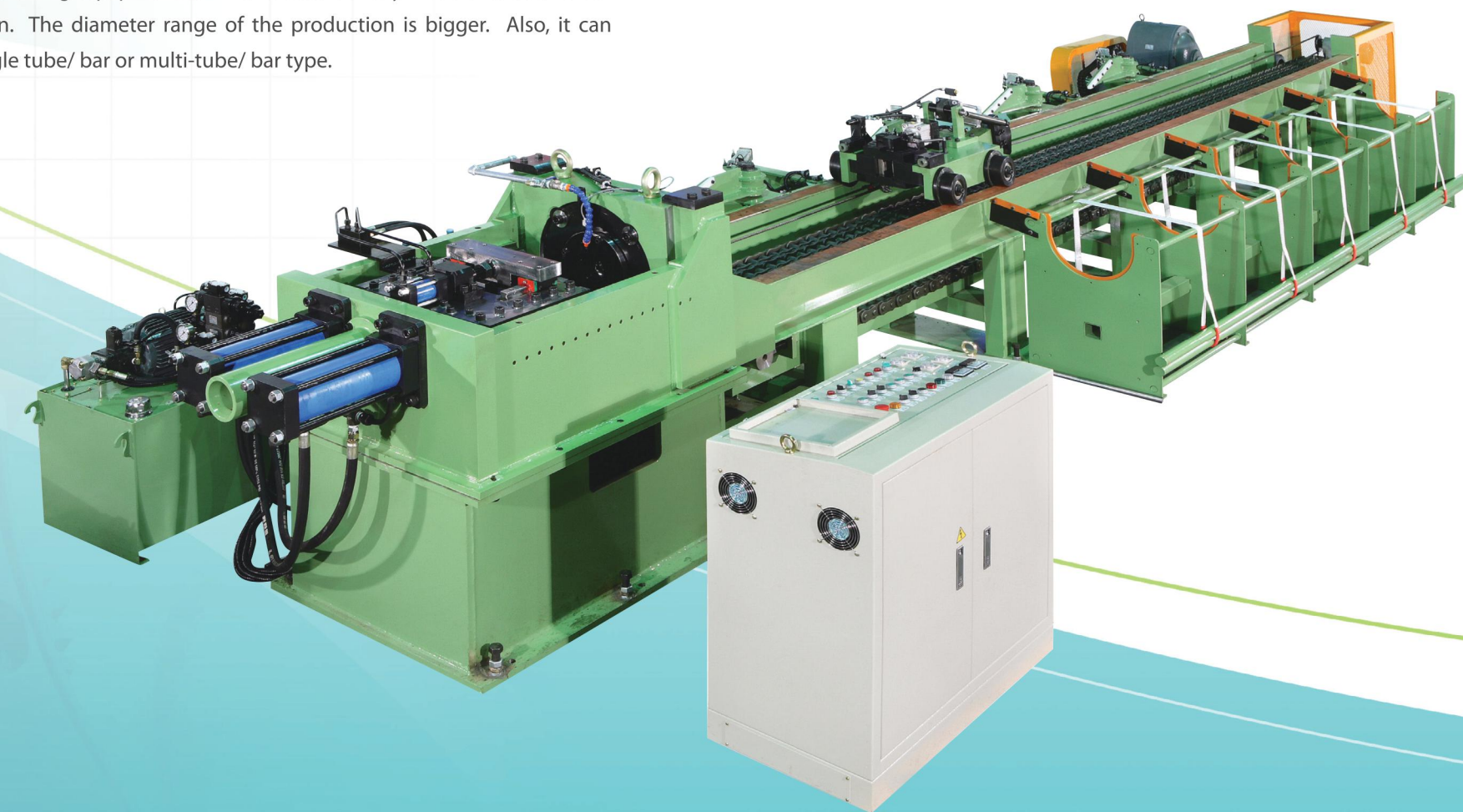



We are the professional
Manufacturer of bar-making machinery

倒角機

CHAMFERING MACHINE

自動車床使用的材料經常需要使用到某些特定加工過的棒材端面，以確認車床入料時無障礙。

省權倒角機的優勢在於：

- 高產能
- 同步執行修面/倒角
- 快速更換刀具

The material for the automatic lathes often requires a certain bar end shape to ensure a trouble-free feed in the lathe.

The advantages of the SHENG CHYEAN Chamfering Machine are:

- High performance
- Facing/chamfering synchronization
- Quick tool replacement

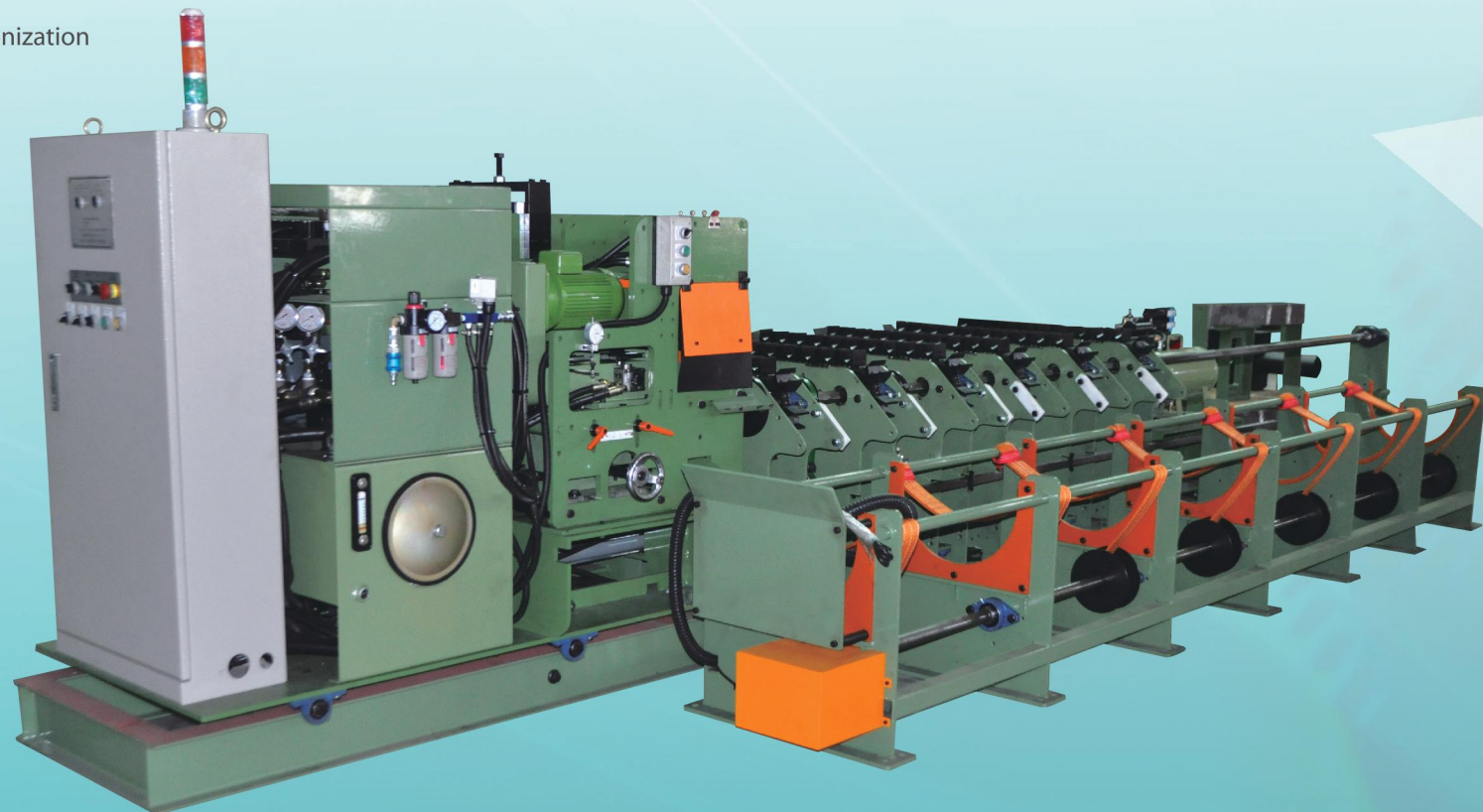

口付機

POINTING MACHINE

此機型是利用動力車削刀頭將棒材頭部外徑削小或端面削尖，以利棒材後續加工或拉拔的進行，同時搭配自動送料/下料系統，以加快生產的效率。

This machine can sharpen and point the end of the bar by power rotating knife head; therefore, the follow-up bar processing and drawing can be done easily. It also equipped with the Auto Loading/ Unloading System to improve the efficiency of the production.

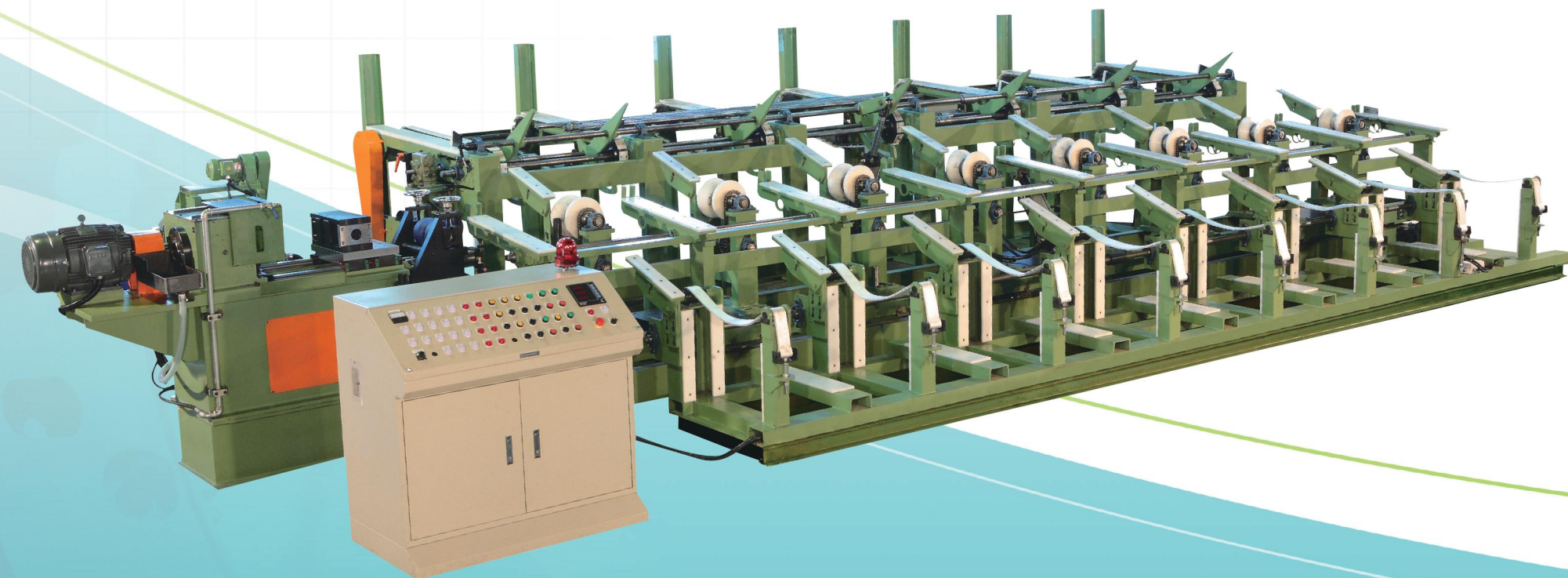



We are the professional
Manufacturer of bar-making machinery

壓延機

FLAT ROLLING MILL MACHINE

本機台包含壓延滾輪組及測徑、拋光、收捲等功能，可將盤捲原料直接加工成扁材，同時拋光材料並將材料收捲整齊，亦可定尺切成異型直棒。

The function of Flat Rolling Mill is including the flat rolling roller, dimension measure, polishing and coiler. It can make the coil material to process the flat material. At the same time, it also can be polished, coiled alignment on line or cut off to bars.

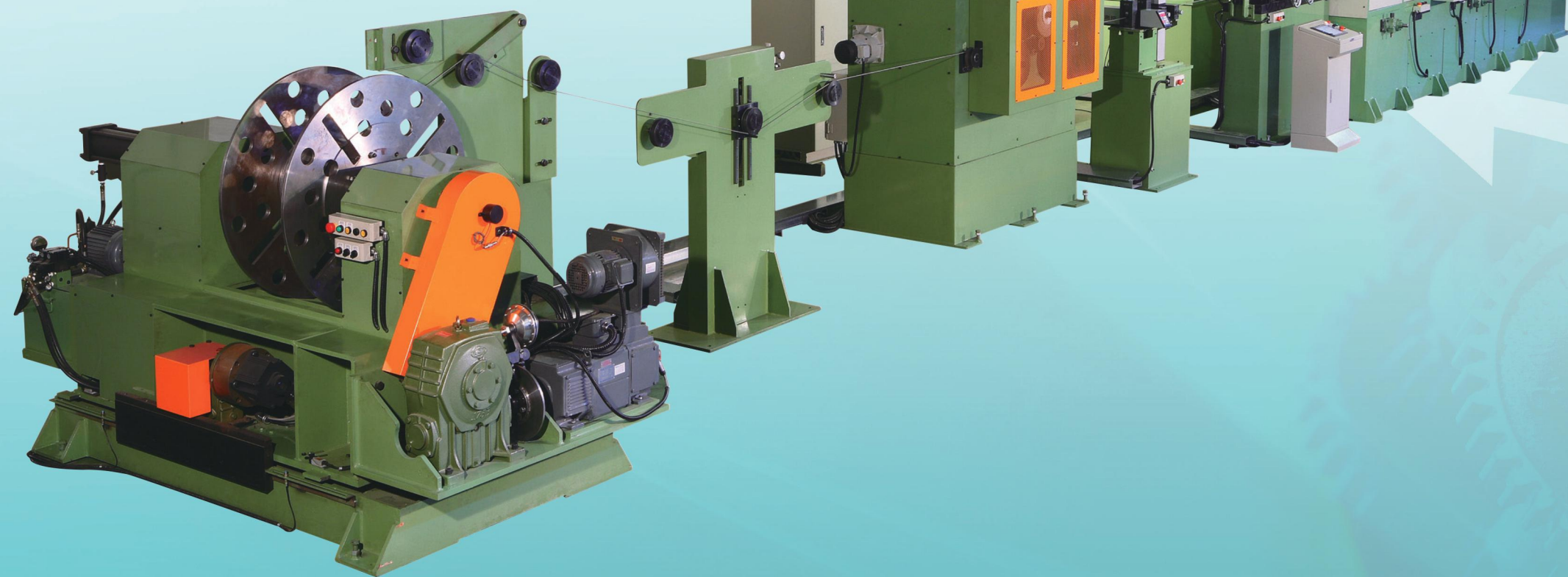

圓棒削皮機

ROUND BAR PEELING MACHINE

此機台可車削去除熱軋棒氧化表面、棒材表面鏽蝕或熱軋開裂等不良表面，加工成精密的光亮棒材且可獲得嚴格尺寸公差。

主要特點：

- (1) 棒材測量和磨損補償：
光學測量儀安裝在出料口後面，這樣可以確保車削刀具經車削後刀具磨損的補償。
- (2) 安全和防護：
本機台的設計已考慮安全性和符合人體工學的工作環境。潤滑劑和冷卻劑在閉合回路系統循環利用。
- (3) 金屬屑回收：
本機台設計自動排屑，能將金屬屑有效的收集。
- (4) 車削入口及出口有中心定位裝置。
- (5) 快速校刀。
- (6) 有效抑制棒材加工過程產生的震動。
- (7) 棒材進料高穩定性，減少削皮刀具損傷機率，使削皮棒擁有高品質的表面。
- (8) 可選擇性與兩輥矯直機做矯直加工。

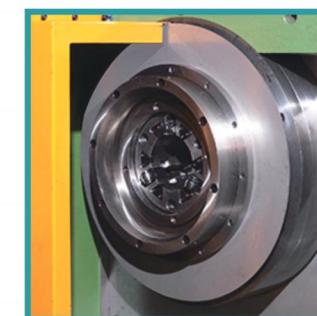

This machine can peel the oxidation and rusty/ crack surface of hot rolled bar and get the precise bright surface and strict size tolerance.

Main character:

- (1) **Bar measure and wear compensation:**
Optic measure device is installed behind of the peeling device exit, so it can compensate the wear of the tool after the turning process.
- (2) **Safety and Protection:**
The design is considered the safety and working environment for the ergonomics. The lubrication and cooling liquid are all circulated in the close circuit system.
- (3) **Metal fillings recycle:**
This machine can exhaust the fillings automatically so the fillings can be collected fully.
- (4) **Center orientation system at the entry and exit of peeling**
- (5) **Correct the tool speedy**
- (6) **Restrain the vibration of the peeled bar during the processing effectively**
- (7) **High stability during the bar feeding and Reduce the damage of the tool to get the best quality surface.**
- (8) **User can choose to process with in-line or off-line Two-Roll Straightening Machine.**

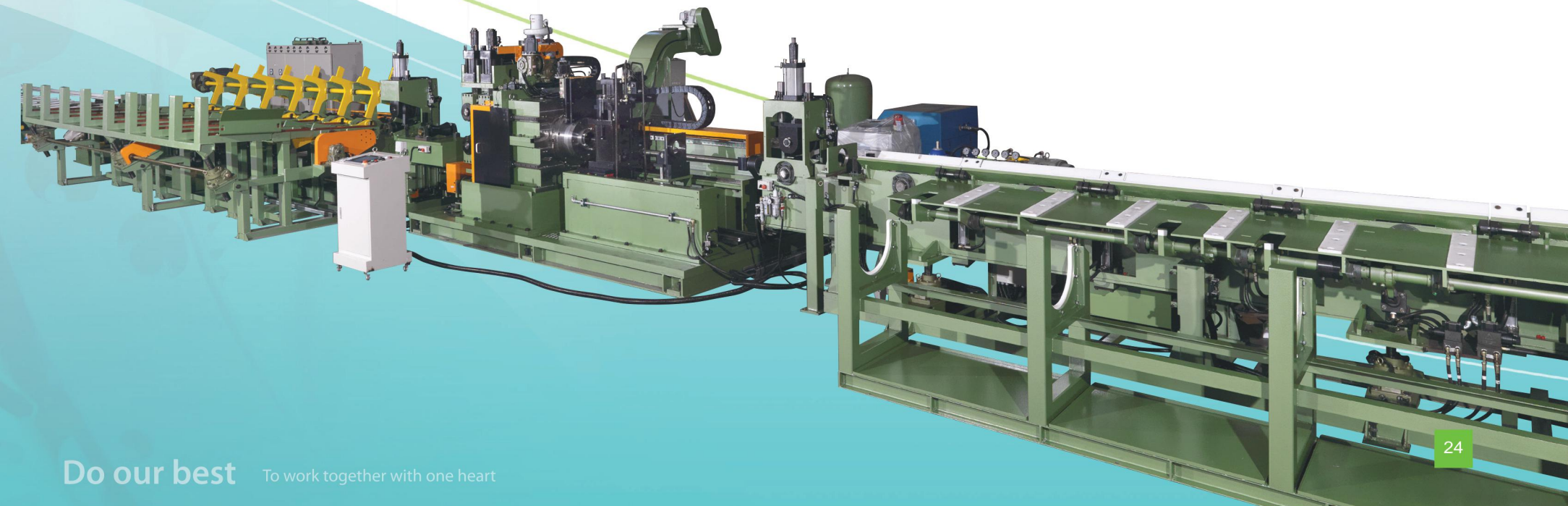



We are the professional
Manufacturer of bar-making machinery

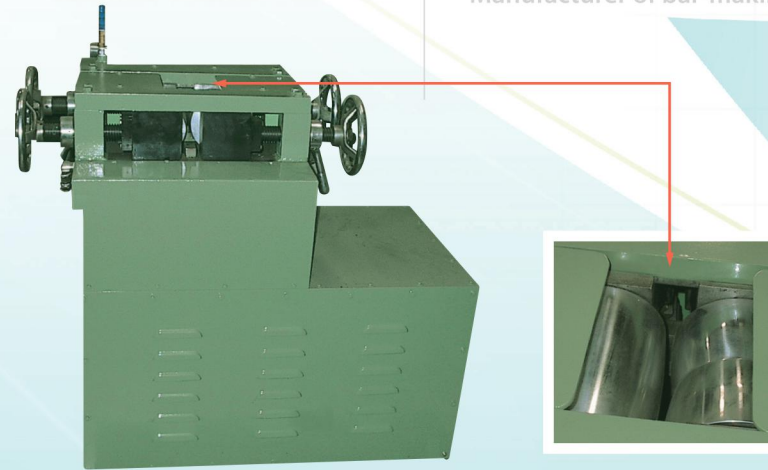

獨立式圓棒矯直機-臥式

INDEPENDENT ROUND BAR STRAIGHTENING MACHINE - HORIZONTAL TYPE

針對圓棒可做棒材矯直，並可搭配前後料架輔助送料及下料。

This machine can straight the round bar. It can equip with the loading and unloading rack to assist the material loading and unloading.

獨立式圓棒矯直機-立式

INDEPENDENT ROUND BAR STRAIGHTENING MACHINE - VERTICAL TYPE

本設備可搭配前後料架輔助送料及下料，對於直度不夠的棒材，利用凹軋及凸輪進行矯直。

This equipment can equip the rack to assist loading and unloading. For the bar which straightness is not enough, concave roller and convex roller can straight it.

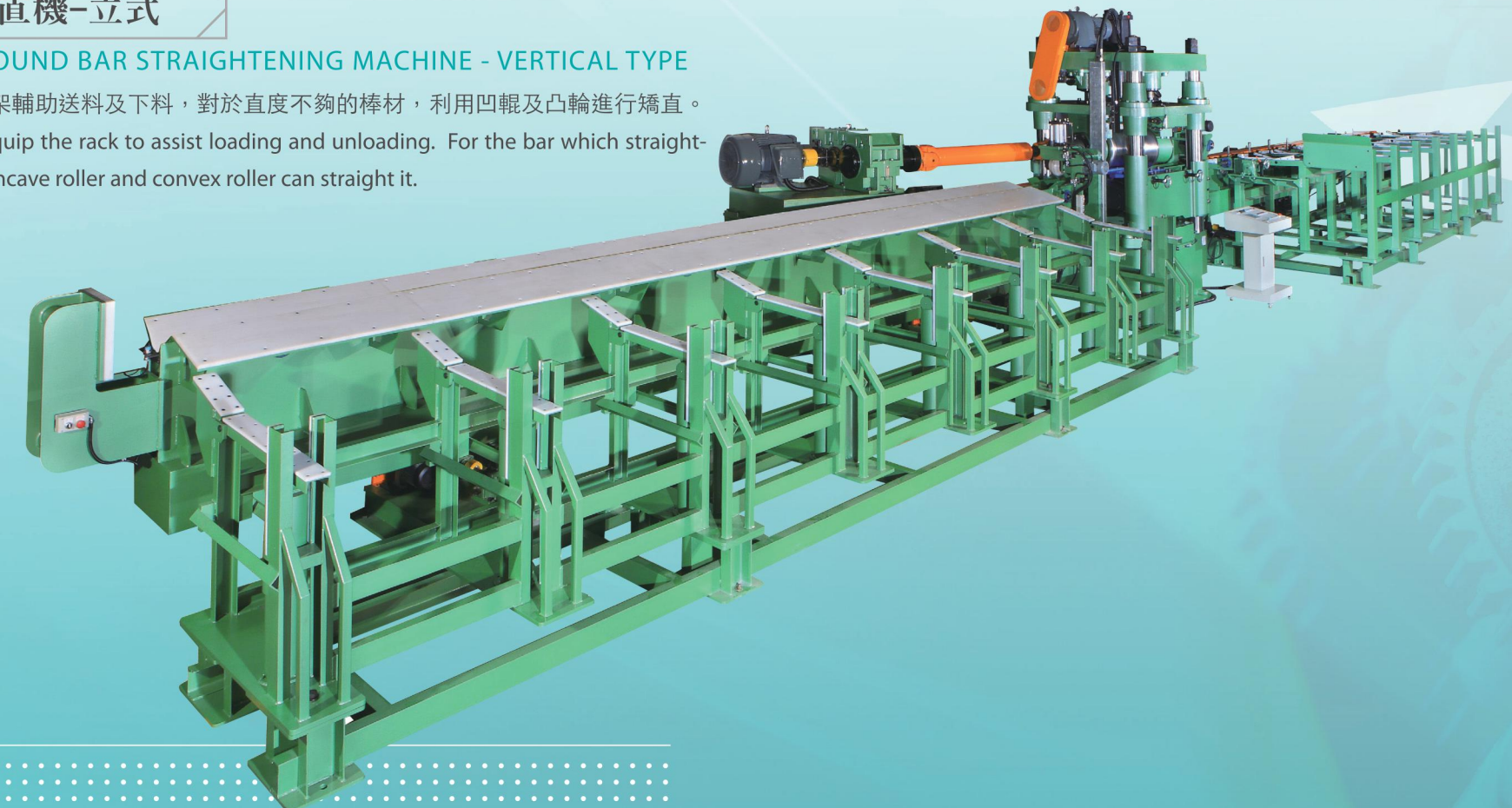

異型棒材矯直機

HEX. AND SQUARE BAR STRAIGHTENING MACHINE

針對六角及四角棒材做矯直，搭配多組軋輪達到需求的矯直效果，且立式與臥式之軋數，可依客戶需求增加組數，更可根據特殊異型材，設計特定的軋面。

This machine can straight the hexagonal and square bar and equipped with multi rollers to achieve required straightness. And the quantity of vertical and horizontal straightening set can be added according to the customer's requirement. Moreover, we also can design the roller curve according to special shaped bar.

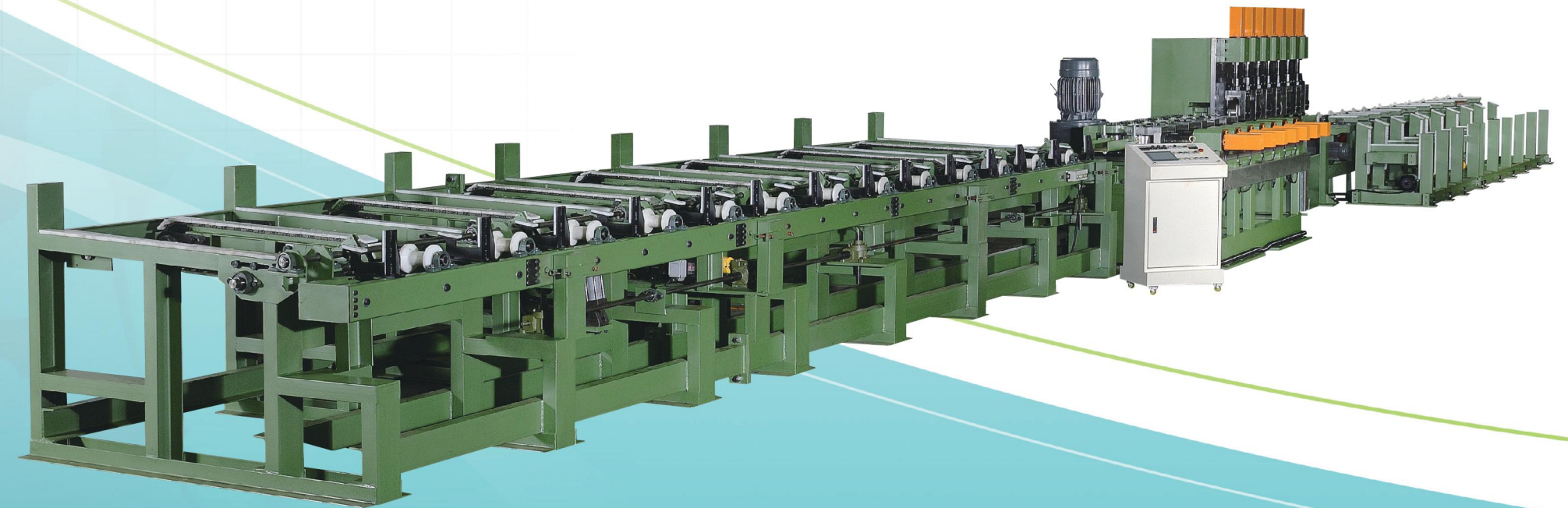
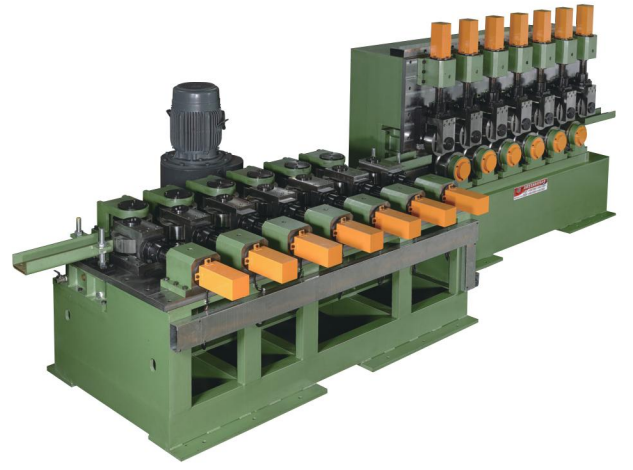



We are the professional
Manufacturer of bar-making machinery

雙砂輪無芯研磨機

DOUBLE GRINDING WHEEL CENTERLESS GRINDING MACHINE

雙面磨削系統提供雙砂輪可大量磨削，並利用錳鋼拋盤設計可做滾壓式拋光。

主要特點：

- (1) 雙砂輪設計提升切削性。
- (2) 錳鋼拋盤設計提升產能及表面精度，並具有高穩定性。
- (3) 改善研磨件真圓度。

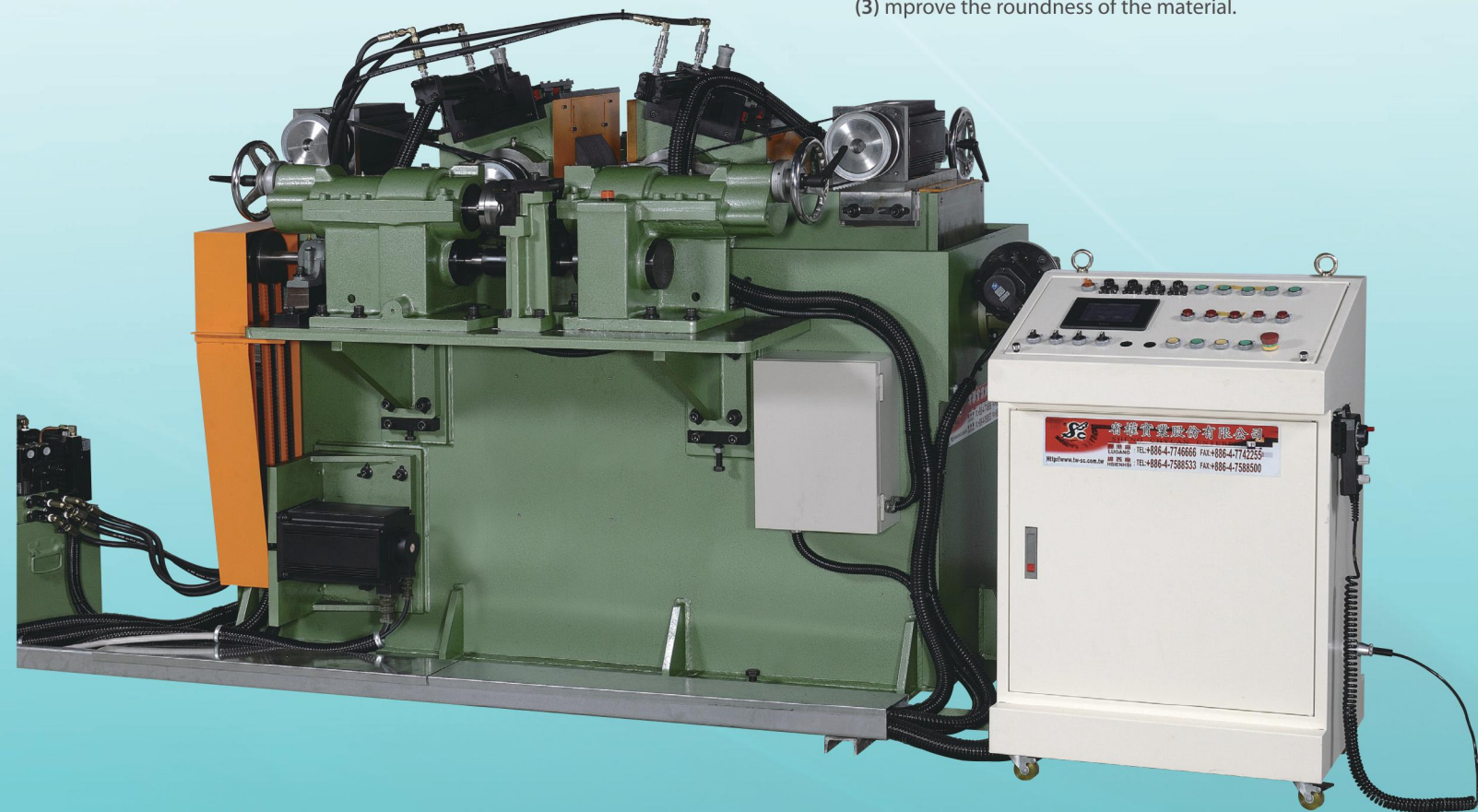

Two side grinding system provides double grinding wheel for numerous grinding.
And equips with Tungsten steel polishing disc can provide roll and press type polishing.

Feature:

- (1) Double Grinding Wheel design increases the cutting quantity.
- (2) Tungsten Steel Polishing Disc design increases the production capacity, surface quality and high stability.
- (3) mprove the roundness of the material.

布輪拋光機

POLISHING MACHINE FOR ROUND TUBE/ BAR

本機適合棒、管材之表面去鏽，兩只不織布輪可選粗細，作一前一後的方式，增加拋光效果，經濟性高。

The machine is suitable for removing the rust of the bar or pipe. Two brushes can be chosen rough or fine and their position is one front and one back to get better polishing efficiency and much economical.



噴砂機

SHOT BLASTING MACHINE

噴砂機之原理是金屬鋼珠，透過高速旋轉之甩輪，形成離心力，打擊在棒材表面上，達到去鏽、去氧化層的功效，可免除酸洗等不環保之作業。

Shot Blasting machine use steel ball and high speed rotation fling roller to get the centrifugal force. Then, it beat on the surface of the bar to remove the rust and oxidation surface. And it can instead of the un-environment pickling.





盤圓料架

COIL PAY-OFF STAND

盤圓料架分為二種型式：

- 90度翻轉盤圓料架
- 360度迴轉式盤圓料架。
- 料架荷重能力：3噸

Coil pay-off stand has two types:

- 90 degree Tilt-able Coil Pay-off Stand
- 360 degree Circumgyration Coil Pay-off Stand.
- Loading weight of Coil Pay-off Stand: 3tons.



360 度迴轉式盤圓料架
360 degree Circumgyration coil payoff stand



90 度翻轉盤圓料架
90 degree Tilt-able coil payoff stand

We are the professional
Manufacturer of bar-making machinery

彎曲度檢查機

BEND-RADIUS EXAMINING MACHINE

此機器是利用量錶測量並得出棒材的直線度，其適用於圓棒、六角棒、四角棒。

This machine uses the gauge to measure the straightness of the bar. Round bar, hexagonal bar and square bar are all available.



複合式伸棒機 Combined Drawing Machine

型號Type	圓材Round (mm)	六角Hexagon (mm)	方材Square (mm)	最大拉力(KG)Max tension	拉拔速度(M)Drawing rate	剪切機制動力矩(N-M) Braking moment for shearing part
SH-0	Ø3~Ø8	H3-H7	S3-S6	2000	80	142
SH-1	Ø5-Ø13	H5-H11	S5-S9	4000	70	142
SH-1B	Ø5-Ø16	H5-H14	S5-S11	6000	60	142
SH-2	Ø10-Ø25	H10-H22	S10-S18	10000	50	525
SH-3	Ø16-Ø36	H16-H31	S16-S25	15000	40	525
SH-4	Ø30-Ø60	H30-H52	S30-S42	40000	20	
型號Type	機組總功率(KW) Total power	機組總重(T) Total weight	杯料最大卷重(T) Weight of steel	成品直線度(mm/m) Straightness of finished products	成品表面粗糙度 Surface roughness of finished products	定尺長度 Cutting length
SH-0	80	12	3.0 (Max.)	0.1< ~ 0.8<	Ra 1.6	2-6M
SH-1	112	16				
SH-1B	145	18				
SH-2	240	31.7				
SH-3	310	58				
SH-4		75				

鏈式拉拔機 Chain Draw Bench

型號Type	馬力HP	能力Capacity	最高速度Max. Speed
SC300	50HP	Ø16~Ø50	25M/min
SC400	100HP	Ø30~Ø75	20M/min
SC500	150HP	Ø50~Ø100	15M/min

圓棒矯直機 Two-Roll Straightening Machine

型式(Type)	RK-0	RK-1	RK-2	RK-3	RK-6	RK-7
棒加工直徑(mm) (Bar diameter)	Ø4~ Ø10	Ø8~ Ø25	Ø18~ Ø35	Ø20~ Ø55	Ø40~ Ø150	Ø50~ Ø180
動力(kw) (Motive power)	10kw x2台	15kw x2台	18.5kw x2台	37kw x2台	75kw x2台	90kw x2台
速度(m/min) (Speed)	5~60	5~45	5~45	5~35	5~10	5~10



We are the professional
Manufacturer of bar-making machinery

圓棒削皮機 Round Bar Peeling Machine

型號Type	加工長度(M) Working Length	原料直徑 (mm) Input Dia.	成品直徑(mm) Finished Dia.	切削深度/半徑(mm/ Radius) Cutting Depth	進料速度(M/ mim) Feeding Speed	主軸轉速(rpm) Spindle Rotation Speed
SHP-2060	2.5~8	25~65	20~60	2.5	15	2000
SHP-2080	2.5~8	25~85	20~80	2.5	10	1500
SHP-50125	2.5~8	55~130	50~125	2.5	5	800

倒角機 Chamfering Machine

型號Type	加工直徑 (Machining diameter)	加工形狀 (Machining shaping)	加工長度 (Machining length)	加工材質 (Machining material)	機型(Model)
SH0310-2060	Ø3~Ø10mm	圓棒、六角棒、四角棒 (Round, Hexagonal and Square bar)	2~6M	銅、鐵、鋁 (Copper, Iron and Aluminum)	吊料自動倒角、連線自動倒角 (Off-Line Automatic Chamfer, In-Line Automatic Chamfer)
SH0516-2060	Ø5~Ø16mm				
SH1025-2060	Ø10~Ø25mm				
SH2050-2060	Ø20~Ø50mm				

壓延機 Flat Rolling Mill

規格 Specification	最大Max	最小Min
加工範圍-直徑 Machining Diameter	14mm	4mm
加工範圍-厚度 Machining Thickness	10mm	1mm
加工範圍-寬度 Machining Width	20mm	6mm
加工速度 Machining Speed	100M/min (Max.)	
坯料大卷重 Weight Of Coil(Max.)	3000kg	
成品最大卷重 Weight Of Finished Products(Max.)	1000kg	
機組總功率 Total Power	265kw	
機台總重(噸) Total Weight (T)	34 Ton	

口付機 Pointing Machine

規格 Specification	
加工直徑 Working Diameter	Ø19~ Ø80mm H 19~H63.5mm S19~S40mm
可加工棒材長度 Working Bar Length	2M~8M
可修頭長度 Pointing Length	400mm
切削深度(半徑) Cutting depth (Radius)	2.0mm
尺寸公差 Diameter tolerance	< 0.8mm
長度誤差 Length tolerance	< 2mm

油壓剪斷機&彎曲機

HYDRAULIC CUTTER & BENDER

充電式油壓剪斷機 Charge-type hydraulic cutter

型號Type	切斷能力Cutting Power	重量 Weight	切斷速度Cutting Speed
HCC-13	13mm	4kg	2.5秒 (second)
HCC-16	16mm	4.5kg	2.5秒 (second)
HCC-19	19mm	5kg	2.5秒 (second)



插電式油壓剪斷機 Plug-in hydraulic cutter

型號Type	切斷能力Cutting Power	重量 Weight	切斷速度Cutting Speed
HBC-313	13mm	5.3kg	1.5秒 (second)
HBC-316	16mm	7.8kg	1.7秒 (second)
HBC-19	19mm	11.8kg	2.5秒 (second)
HBC-25	25mm	20kg	4.0秒 (second)
HBC-32	32mm	30kg	6.0秒 (second)



插電式油壓彎曲機 Plug-in hydraulic bender

型號Type	彎曲角度 Curve Angle	彎曲能力 Curve ability	重量 Weight
HBB-32	0~90°	32mm	19kg
HBB-25	0~90°	25mm	11.5kg





自動倉儲

AUTOMATIC WAREHOUSE

利用電腦管理的自動化倉儲系統，可降低人工及管理費用，儲存立體化、搬運自動化、大幅改善工作及儲存環境，提升效率...等等，基於以上種種的優點，自動倉儲系統已廣泛的在國際間得到認同，更是企業界在管理上的一大助力。

倉儲有三大系列：

- 棧板式：載重2噸左右（最重）
- 貨籃式：載重40KG左右（最重）

Automatic warehouse system is managed by computer, and it can reduce the manpower and management expense. "Solid Storage" and "Automatic Carry" can improve the working and storage environment and then can promote the efficiency. On the basis of many advantages, automatic warehouse system already has the identification internationally. Also, it is very important for the management.

There are two series of warehouse:

- Pallet type: Loading weight is around 2 tons. (Maximum)
- Basket type: Loading weight is around 40KG. (Maximum)

棧板式 Pallet type



We are the professional
Manufacturer of bar-making machinery

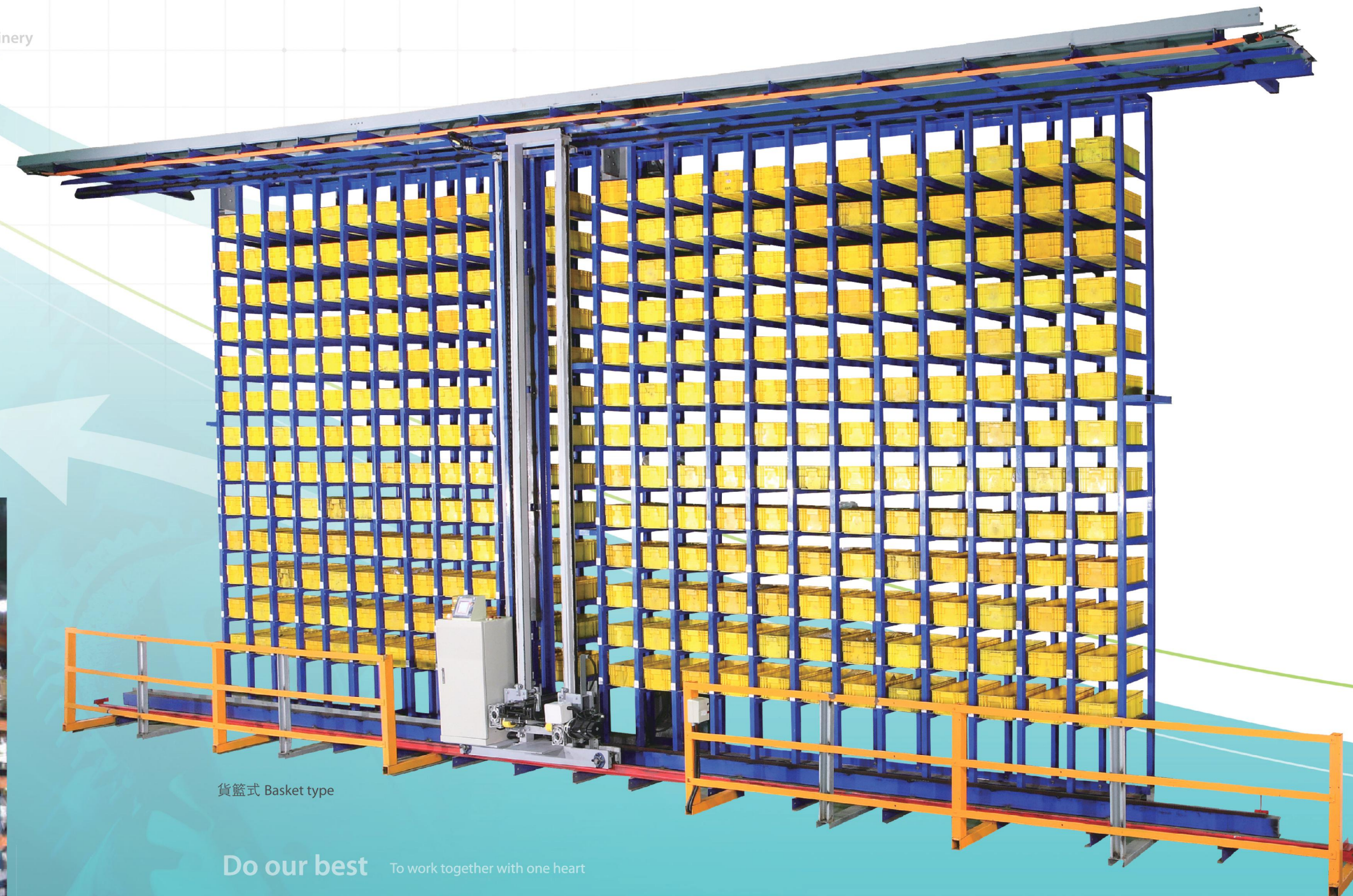

貨籃式 Basket type

Do our best To work together with one heart